

User Manual

Intelligent badminton
training machine



*Easy movement by science
and technology*

Forbid minors to operate or clean the machine ,avoid damage the machine or any danger.

Thanks for choosing intelligent badminton training machine.
Please read this manual carefully before operating with the machine.

Catalogue

1.Parts list of machine

- Parts list①
- Installation step①

2.Instructions

- Integral structure and lifting operation②
- Instructions for remote control panel②
- Remote control instructions③
- Common pattern and reference settings.....③
- Badminton court and Programme drop point diagram ④

3.Function parameters

- Main function④
- Product parameters④

4.FAQ

- Notice.....⑤
- Common faults and solutions⑤

Product parameters			
Frequency	1.2-4.5s/ball	Speed	20-140 km/h
Capacity	200PCS	Power	120W
Elevation	38° ~-13° (by remote)	Horizontal	30° (by remote)
Height of serving mouth	min height above the floor:135-140cm max height above the floor:210-215cm	Lifting system	fixed or 0-75cm can be adjusted by manual

NO.4 FAQ

Notice

- ▲Do not disassemble or change the machine voluntarily.
Otherwise it will damage the machine or result in serious accident.
- ▲Don't place the machine in direct sunlight for a long time to prevent plastic rubber from aging.
- ▲Do not train the machine with moist, stained and damaged balls, otherwise it will cause faults such as jamed balls or even broken the machine.
- ▲Turn off the power and take out the ball right away when play the shuttlecocks inside of the machine, otherwise it will cause the accident or damage the machine .
- ▲If the machine has an unusual situation, for example: big noise, strong smog and leakage, please immediately cut the power, then contact with local service provider or manufacturer.
- ▲Do not move it during working.
- ▲Do not operate the power or switch of the machine by wet hand, otherwise it will cause electric shock.
- ▲Do not touch the internal components by hand when the machine in working, to avoid an accident.
- ▲Forbid minors operate machine or clean internal of machine to avoid damage the machine or cause personal danger.

Common fault and solution

Fault phenomenon	Reason	Solution
Machine doesn't work	①AC power cord has damaged or not plugged in ② Check the fuse	①Change or plugged in AC power cord ② change a new fuse
The machine serving two or more shuttlecocks at one time	① The old shuttlecocks adhere together ② The shuttlecocks are broken	① Seperate the shuttlecocks ② Change new shuttlecocks
Shuttlecocks jamed	① The basket holder or the shuttlecock don't put in it's position ② The feather of the shuttlecock is broken ③ The fairway is not smooth	① Put the basket holder or shuttlecocks in right position ② Change new shuttlecocks ③ Clear the fairway
Serving normal but basket don't move	The inductor is dirty and can not receive signal	Clear the inductor avoid it is blocked by dust
Ball can't pick up	① The materical of theshuttlecocks is different ② The inductor is dirty	① Use the same shuttlecocks ② Clean the inductor

(4)Program:1.Place the machine 50cm distance from front service line,adjust lifting column to the highest,then set speed as 140km/h. 2.Place the machine 120cm distance from front service line,adjust lifting column to the lowest then set speed as 140km/h.

(5)Net shot: Place the machine 50cm distance from rear service line,set speed as 140km/h,vertical display 27.

(6)Random:Place the machine 50cm distance from front service line.Some of drive balls will be outside side line.

5.Badminton court and Programme drop point diagram

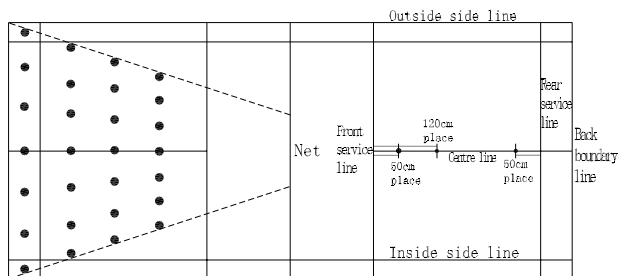

PS:The point of fall depends on the ball material and the position of the machine.different setting has a slight deviation.

Function introduction	
NO.	Description
1	Smart remote control with full function(speed,frequency,horizontal angle,etc.)
2	Intelligent placement programming,you can program different serving mode to train
3	High performance of photoelectric sensors makes the machine runs more stably and reliably.
4	Infinite adjustment of remote control of the elevation and horizontal angle, arbitrary choice of placement
5	The battery can last 3-5 hours,allowing you play with enough fun
6	Automatic lifting column,you can choose go up or bring down the lifting column by touch lifting button
7	Wide voltage is 100V to 240V(over current, over voltage protection),use without care
8	Unparalleled elevationangle adjustment system, serve up to 8 m
9	Allowing you experience the best training effect with unique smash function and fast speed
10	Remote control with LCD screen is more convenient and clearly
11	You can remote any elevation angle and two line function(left,middle and right)
12	Random function
13	One button on the remote control to choose six kinds of cross ball
14	One button on the remote control to choose different horizontal ball
15	One button on the remote control to choose different elevation of the ball
16	The key components: shooting wheels and the main motor with high quality materials are durable,motor service life can be up to 10 years
17	Suitable for any type of shuttlecocks(nylon ball, plastic ball and soon)
18	Machine is easy to install and transport with lightweight, portable handle
19	The stander can be fast to fold, bottom is equipped with a moving wheels with brake,easy and convenient to move
20	Large capacity:200pcs
21	Accessories comes standard :remote control,charger,and connect cable
22	Fashion design,can be placed in the trunk of any cars, easy to carry

NO.1 Parts list of machine

Please check the parts according to the following list when the machine unpacked.

NO.	Item	Picture	NO.	Item	Picture
1	Power cable		6	Shuttlecock holder	
2	DC connect cable		7	Remote control	
3	Basket holder pin		8	battery of 7th	
4	Wrench 2pcs (2.5mm and 3mm)		9	lithium battery	
5	Tripod (with lifting)		10	Charger	

Installation steps

image 1:Shuttlecock holder and main machine installation

image 2:main machine installation

image 3:Shuttlecock holder installation

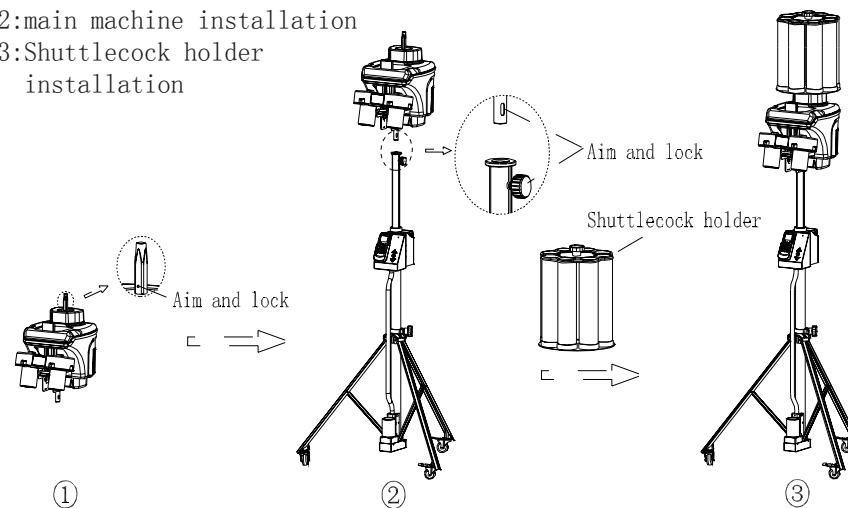

- (1) As image 1,please install the basket holder pin on the top of main machine,the screw should aim at the flat position of the bolt,then use the 2.5mm wrench lock the screw.
 - (2) Please aim at the holder pin at the top of main machine and put the basket on it when you install the basket to the main machine
- Mark:You need turn off the power and wait till the holder pin stop moving ,then put the basket on the holder pin.

NO.2 Instructions

1. Integral structure and lifting operation

Fix the tripod, when you need to rise the tripod, touch "Rise up" button, the lifting column start to go up, when it reach the height you want, touch "Stop" button, it will stop.

When you need to drop down the tripod, touch "Drop" button the lifting column start to drop down, when it reach the height you want, touch "Stop" button, it will stop.

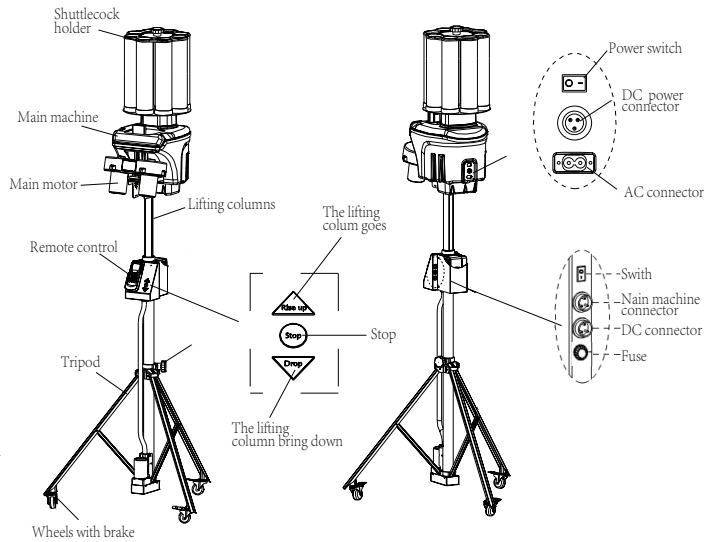

2. Introduction for remote control panel

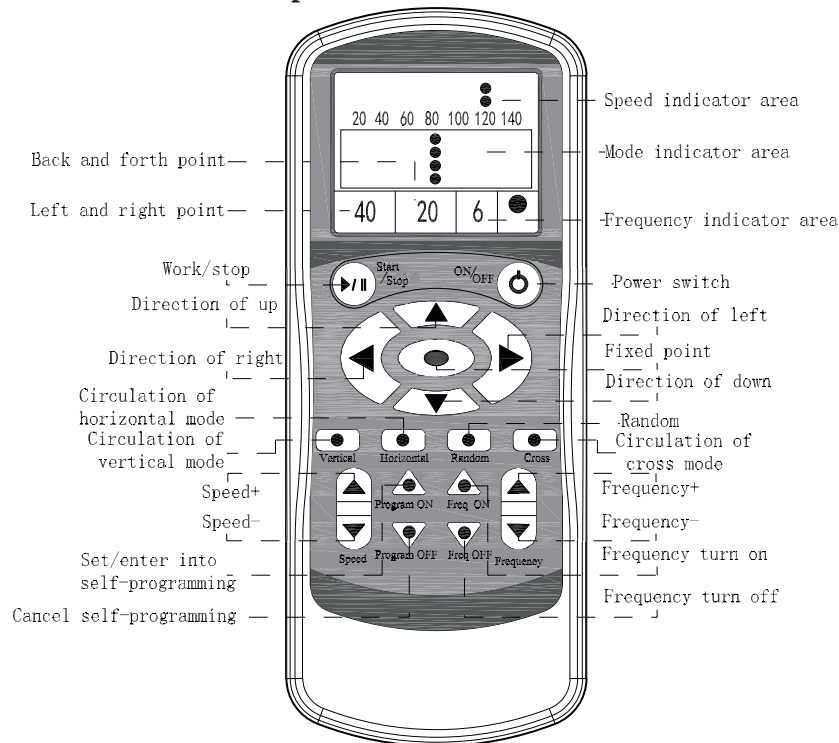

②

3. Remote control instructions

- (1) Fixed point mode: touch fixed point button to enter into fixed point. you can change the direction by "up", "down", "left", "right".
- (2) Vertical mode: touch first enter into vertical movement, touch twice enter into high-low ball.
Mark: you can change the direction by touching "left" and "right".
- (3) Horizontal mode: touch first enter into left to right circulation movement, touch twice enter into wide two line ball, touch third enter into middle two line ball, touch fourth enter into narrow two line ball, touch fifth enter into three line ball.
Mark: you can change the direction by touching "up" and "down".
- (4) Random mode: free serving of the whole court.
- (5) Cross mode: Touch first is light ball of left and deep ball of middle, touch twice is deep ball of left and light ball of middle, touch third is light ball of middle and deep ball of right, touch fourth is deep ball of middle and light ball of right, touch fifth is light ball of left and deep ball of right, touch sixth is deep ball of left and light ball of right.
- (6) Set/enter into self-programming:
 1. touch the button for 3 seconds longer to enter into self-programming, when there is a twinkling point on the screen, then it's the placement.
 2. you can choose the location by touching "up", "down", "left", "right".
 3. you can touch the "self-programming" button to store the placement when you adjust it to the placement that you want.
- (7) Cancel of self-programming:
 1. firstly you can choose the placement by touching "up", "down", "left", "right"
 2. you can cancel the placement when you adjust it to the placement that you want to cancel.
 3. touch "cancel of self-programming" for 3 seconds longer to cancel all the placement.

Note:

- (1) Turn on remote: The machine is designed with shooting delay function, press "power switch" button in order to start the remote. the machine will shoot automatically after 5 seconds when press "work/pause", do not stand in front of the machine avoiding accident.
- (2) Turn off remote: Press "work/pause" or any button to wake up the remote, long press the "NO/OFF" button to turn off the remote.

4. Common pattern and reference settings

- (1) Back court clear: Place the machine 50cm distance from front service line, adjust the vertical angle to the highest point, and adjust lifting column to the highest, then set speed as 140km/h, drop point will be 30-50cm distance inside side line.
- (2) Bottom smash: Place the machine 50cm distance from front service line, adjust the vertical angle to the lowest point, and adjust lifting column to the highest, then set speed as 140km/h, drop point will be 1.3m distance from front service line.
- (3) Clear&drive: Place the machine 1.2m distance from front service line, adjust lifting column to the lowest then set speed as 140km/h, vertical display 23, drop point will be corners of backcourt.

③